

Translated English of Chinese Standard: GB/T22309-2023
www.ChineseStandard.net → Buy True-PDF → Auto-delivery.
Sales@ChineseStandard.net

GB

NATIONAL STANDARD OF THE
PEOPLE'S REPUBLIC OF CHINA

ICS 43.040.40

CCS Q 69

GB/T 22309-2023

Replacing GB/T 22309-2008

**Road vehicles - Brake linings - Shear test method for disc
brake pad and drum brake shoe assemblies**

道路车辆 制动衬片 盘式制动块总成和鼓式制动蹄总成剪切强度试
验方法

Issued on: December 28, 2023

Implemented on: July 01, 2024

**Issued by: State Administration for Market Regulation;
Standardization Administration of the People's Republic of China.**

Table of Contents

Foreword.....	3
Introduction.....	5
1 Scope.....	6
2 Normative references	6
3 Terms and definitions.....	6
4 Symbols.....	7
5 Sample preparation	7
6 Test equipment and fixtures	8
7 Test procedure	11
8 Calculation of results	11
9 Test report	12
Appendix A (Informative) Test flow chart.....	14
Appendix B (Informative) Format of test report.....	15
References.....	16

Road vehicles - Brake linings - Shear test method for disc brake pad and drum brake shoe assemblies

1 Scope

This document describes the sample preparation, test equipment and fixtures, test procedure, calculation of results and test report for the shear strength test method for disc brake pad assembly and drum brake shoe assembly.

This document applies to the determination of shear strength of automotive disc brake pad assembly and drum brake shoe assembly that are integrally molded, bonded, or fitted using the two types of systems. This document is not applicable to the determination of shear strength of riveted automobile brake pad (shoe) assemblies.

2 Normative references

The following documents are referred to in the text in such a way that some or all of their content constitutes requirements of this document. For dated references, only the edition cited applies; for undated references, the latest edition of the referenced document (including any amendments) applies.

GB/T 5620, Road vehicles - Vocabulary and definition for braking of automotive vehicles and their trailers

3 Terms and definitions

Terms and definitions determined by GB/T 5620, as well as the following, are applicable to this document.

3.1

lining

Friction material component of the brake assembly.

3.2

bond area

Contact area between the lining and the back plate or shoe.

3.3

Note: During the test, the shear force loaded on the sample and the auxiliary pressure acting on the sample are of inconsistent directions. If the groove is inclined or higher than the back plate, the test results will be affected.

Figure 1 – Sample of drum brake shoe assembly segment

6 Test equipment and fixtures

6.1 Test equipment

6.1.1 The test equipment shall be a press or tensile machine or similar machine (such as a shear testing machine) which applies sufficient shear force by driving the indenter.

6.1.2 The test equipment shall be provided with a recording device, which can correctly record the instantaneous failure shear force.

6.1.3 The test equipment shall be capable of controlling the loading rate so that the average loading rate is $(4\ 500 \pm 1\ 000)$ N/s (depending on the vehicle type being evaluated). If a constant-speed crosshead testing machine is used, the crosshead speed is (10 ± 1) mm/min. Record the category of control of the testing machine (loading rate or crosshead speed) on the test report, so that the results can be compared between different test equipment. Avoid any impact load during the test.

6.2 Test fixtures

6.2.1 General

The shear test fixture shall be able to hold the sample and be parallel to the indenter. To avoid sharp edges, the part of the fixture in contact with the sample shall be rounded with a radius of no more than 2 mm. If a specific radius is used, record it in the test report to avoid deviation from the test procedure. If the surface area of the fixture contains draft angles, indicate it in the test report.

6.2.2 Drum brake shoe assembly

6.2.2.1 The fixture shall be designed such that the indenter is in consistent contact with the contour surface of the lining along the length direction and has a gap of (1 ± 0.2) mm from the arc surface of the drum brake shoe (see Figure 2). For the lining bonded or molded to the shoe, the maximum distance from the bonding surface shall be 0.2 mm.

- ^c – surface load;
- ^d – the minimum friction on the contact surface;
- ^e – not greater than the thickness of the back plate.

Figure 3 – Disc brake pad test fixture

7 Test procedure

7.1 Carry out the test at room temperature of (23 ± 5) °C. If testing under other environmental conditions is required, an agreement shall be reached with the customer.

7.2 When a high-temperature shear test is required, the sample shall be placed in an oven, heated evenly from room temperature to the test temperature within (30 ± 2) minutes, and then taken out of the oven, which shall be completed within 60 s. The test temperature of drum brake lining is (200 ± 10) °C, and the test temperature of disc brake pad is (300 ± 10) °C.

7.3 Place the drum brake shoe or disc brake pad in the appropriate shear test fixture in the direction indicated by the test (radial or tangential).

7.4 Apply load at the rate specified in 6.1 until the sample fails.

7.5 Record the failure load and express the residual area of the friction material after the shear test of the disc brake pad or drum shoe as a percentage in accordance with the provisions of Chapter 9. Evaluate the fracture surfaces at the uncut edge (2 mm from the brake pad or shoe profile) and the core area, respectively. If there is any objection to the visual evaluation, use the following reference scheme for analysis (optional):

- Mix to prepare 1.0 L of reference solution: 80 g of CuSO₄, 30 g of NaCl, 100 mL of 0.01 mol/L HCl (adding 0.364 6 g of HCl to 1 L of solution), add distilled water or deionized water to make the total volume of the solution 1.0 L;
- Immerse the back plate into the reference solution for 5 seconds;
- Evaluate the fracture condition and record it as follows: When the reference solution does not dye the broken surface brown, the material has broken; If there is bond failure between the glue and the back plate, regular and uniform brown will appear on the broken surface.

7.6 See Appendix A for the test procedure.

8 Calculation of results

8.1 Calculate the shear strength according to Formula (1):

$$\tau = \frac{F}{A} \dots\dots\dots (1)$$

8.2 Calculate A based on the friction material bonding profile instead of the pad surface, and remove the grooves. Express the shear strength by the minimum value and the average value of samples.

9 Test report

The test report (see Appendix B) shall include the following contents.

- a) Product model, supplier and batch number of drum brake shoe assembly or disc brake pad assembly.
- b) Type of sample and direction of loading, when testing using a part of the assembly or a prepared sample.
- c) Number of samples.
- d) Minimum and average values of shear force, or minimum and average values of shear strength, or all of the above.
- e) Fixture with/without draft angle.
- f) Expression of the shear test results (evaluated with reference to the shear fracture diagram in Figure 4), including the following information:
 - 1) Failure percentage (smooth surface, bonding layer and lining layer);
 - 2) Area and location of smooth surface area.
- g) Test conditions different from those specified in Chapter 5, such as special test temperature.

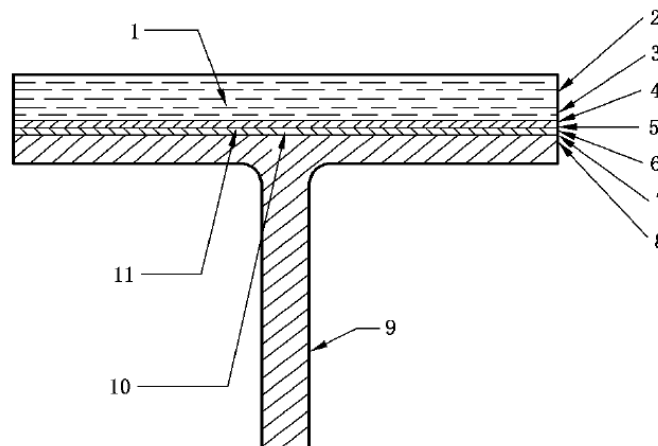

This is an excerpt of the PDF (Some pages are marked off intentionally)

Full-copy PDF can be purchased from 1 of 2 websites:

1. <https://www.ChineseStandard.us>

- SEARCH the standard ID, such as GB 4943.1-2022.
- Select your country (currency), for example: USA (USD); Germany (Euro).
- Full-copy of PDF (text-editable, true-PDF) can be downloaded in 9 seconds.
- Tax invoice can be downloaded in 9 seconds.
- Receiving emails in 9 seconds (with download links).

2. <https://www.ChineseStandard.net>

- SEARCH the standard ID, such as GB 4943.1-2022.
- Add to cart. Only accept USD (other currencies - <https://www.ChineseStandard.us>).
- Full-copy of PDF (text-editable, true-PDF) can be downloaded in 9 seconds.
- Receiving emails in 9 seconds (with PDFs attached, invoice and download links).

Translated by: Field Test Asia Pte. Ltd. (Incorporated & taxed in Singapore. Tax ID: 201302277C)

About Us (Goodwill, Policies, Fair Trading...): <https://www.chinesestandard.net/AboutUs.aspx>

Contact: Wayne Zheng, Sales@ChineseStandard.net

Linkin: <https://www.linkedin.com/in/waynezhengwenrui/>

----- The End -----